

(4C) HL TECK

Four Conductor, XLP Insulated, PVC Inner Jacket, Aluminum or Steel Armor, PVC Outer Jacket, 600 Volts

APPLICATION:

As 600 volt Type MC cable rated 90°C in wet or dry locations; for installation aerially, in metal rack, trough, cable tray, or direct buried; for power and control circuits not exceeding 600 volts in manufacturing and processing plants, substations and generating stations. May be used in NEC Class I and II, Div. 2 and Class III, Div. 1 and 2 hazardous locations.

STANDARDS:

1. Listed by UL as Type MC cable per Standard 1569.
2. Individual conductors UL listed as Type XHHW-2 per UL Standard 44.
3. Jackets UL listed as Sunlight Resistant.
4. Cables UL listed for Direct Burial.
5. Cables pass UL and IEEE-383 ribbon burner flame tests and are UL listed For CT Use.
6. Cables pass ICEA 210,000 BTU/hr. ribbon burner flame test.
7. Cables conform to ICEA S-95-658, NEMA WC70 for Nonshielded Power Cables Rated 2000 Volts or Less.

CONSTRUCTION: Four conductors of stranded uncoated copper, XLP (crosslinked polyethylene) insulation, surface print phase identification, twisted with one uncoated copper grounding conductor, suitable fillers, binder tape, PVC inner jacket, aluminum or galvanized steel interlocked armor, PVC jacket overall.

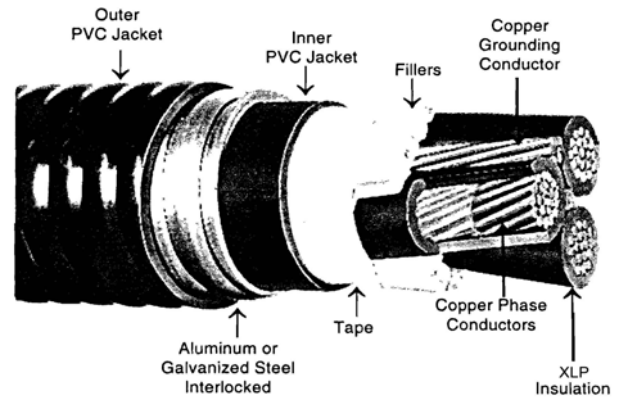

USAWC Part #	Size AWG or kcmil	No. of Strands	Insul. Thick. Mils	Inner PVC Jkt. Mils	Nom. Diam. Inner Jkt. Inches	Nom. Diam. Over Armor Inches	Outer PVC Jkt. Mils	Nom. Cable Diam. Inches	Copper Grounding Conductor AWG	Weight lbs/ 1000 ft		Ampacity* 90°C
										Alum. Armor	Copper	
8-04WGTECK90	8	7	45	50	.72	.93	50	1.03	10	588	236	44
6-04WGTECK90	6	7	45	50	.83	1.03	50	1.13	8	778	375	60
4-04WGTECK90	4	7	45	50	.93	1.13	50	1.23	8	1024	567	76
3-04WGTECK90	3	7	45	50	1.02	1.27	50	1.37	6	1241	733	88
2-04WGTECK90	2	7	45	50	1.08	1.35	50	1.45	6	1471	889	104
1-04WGTECK90	1	19	55	50	1.18	1.43	50	1.53	6	1807	1113	120
1/0-04WGTECK90	1/0	19	55	50	1.28	1.55	60	1.67	6	2183	1385	136
2/0-04WGTECK90	2/0	19	55	50	1.38	1.65	60	1.77	6	2602	1725	156
3/0-04WGTECK90	3/0	19	55	50	1.50	1.79	60	1.91	4	3176	2201	180
4/0-04WGTECK90	4/0	19	55	60	1.66	1.93	60	2.09	4	3859	2745	208
250-04WGTECK90	250	37	65	60	1.86	2.13	75	2.25	4	4328	3217	232
350-04WGTECK90	350	37	65	60	2.11	2.39	75	2.54	3	5811	4487	280
500-04WGTECK90	500	37	65	75	2.47	2.71	75	2.92	2	8070	6378	344
600-04WGTECK90	600	61	80	75	2.73	3.01	75	3.18	2	9545	7614	380
750-04WGTECK90	750	61	80	75	2.98	3.25	85	3.42	1	11817	9523	428

*AMPACITY in accordance with the NEC for cables installed in uncovered cable tray without maintained spacing at the conductor temperature indicated in wet or dry locations, 30 C ambient temperature

Specification

HL TECK INTERLOCKED ARMOR POWER CABLE, TYPE MC

Four Conductor, XLP Insulated, PVC Inner Jacket, Aluminum or Steel Armor, PVC Outer Jacket, 600 Volts

1. SCOPE
 - 1.1 This specification describes four conductor XLP (thermosetting crosslinked polyethylene) insulated, aluminum or galvanized steel interlocked armor Type MC power cable having PVC jackets under and over the armor for use in circuits not exceeding 600 volts phase-to-phase at conductor temperatures of 90°C in wet or dry locations for normal operation, 130°C for emergency overload conditions and 250°C for short circuit conditions. Cables are intended for installation indoors or outdoors, aerially, in metal rack, trough or cable trays, or for direct burial.
2. STANDARDS
 - 2.1 The following standards shall form a part of this specification to the extent specified herein:
 - 2.1.1 UL Standard 1569 for Type MC cable.
 - 2.1.2 UL Standard 44 for Type XHHW-2 conductors.
 - 2.1.3 ICEA Pub. No. S-95-658, NEMA Pub. No. WC7D for Nonshielded Power Cables Rated 2000 Volts or Less.
3. CONDUCTORS
 - 3.1 Class B stranded annealed uncoated copper per Part 2 of ICEA.
4. SEPARATOR
 - 4.1 A suitable separator over the conductor may be used at the option of the manufacturer.
5. INSULATION
 - 5.1 Shall be XLP crosslinked polyethylene meeting the requirements of ICEA Table 3-7, Type X-2 and Type XHHW-2 requirements of UL 44. Average thickness of insulation shall be as specified in UL 44 for Type XHHW-2 conductors and in Table 3-4, Column B of ICEA. Minimum thickness at any point shall be not less than 90% of the specified average thickness.
6. PHASE IDENTIFICATION
 - 6.1 Insulated phase conductors shall be printed with the numerals "1", "2", "3" and "4" on the surface of the insulation.
7. ASSEMBLY
 - 7.1 Four phase conductors shall be cabled together with a Class B stranded, uncoated copper grounding conductor and suitable nonhygroscopic fillers to make round. Length of lay shall not exceed 35 times the phase conductor diameter. The grounding conductor shall comply with the requirements of UL Standard 1569. A suitable non-hygroscopic cable tape shall be applied over the assembly.
8. INNER PVC JACKET
 - 8.1 Shall be PVC meeting the requirements of ICEA Table 4-1 and the Sunlight Resistant requirements of UL 1569. Average jacket thickness shall be in accordance with UL 1569. Minimum thickness at any point shall be not less than 70% of the specified average thickness.
9. ARMOR
 - 9.1 Aluminum or galvanized steel interlocked armor shall be applied over the inner PVC jacket. Armor shall be in accordance with UL requirements for Type MC cable and Paragraph 4.3.3 of ICEA.
10. OUTER PVC JACKET
 - 10.1 Shall be PVC meeting the requirements of ICEA Table 4-1 and the Sunlight Resistant requirements of UL 1569. Average jacket thickness shall be in accordance with UL 1569. Minimum thickness at any point shall be not less than 70% of the specified average thickness.
11. IDENTIFICATION
 - 11.1 An ink print legend shall be applied to the surface of the PVC outer jacket providing cable and manufacturer identification.
12. TESTS
 - 12.1 Conductors and completed cables shall be tested in accordance with UL requirements for Type MC cables having XHHW-2 conductors.
 - 12.2 Cables shall be capable of passing the ribbon burner cable tray flame test requirements of UL and shall be UL listed "For CT Use".